



WC1248BD

Industry Standards

UL 508, Types 12 & 13
CSA Certified, Type 12 & 13
NEMA/EEMAC Types 12 & 13

 UL Files E64791

 CSA File LL66078

FEATURES-SPECIFICATIONS

Applications

Designed to hold electrical and electronic controls and instruments. Pushbuttons, pilot lights, meters, switches etc., can be mounted on sloping control surfaces. Interior components can be mounted on standard back panel and terminal straps. Heavy duty construction provides protection from dirt, dust, oil and water.

Construction—Body

- Bodies and doors fabricated from 14 gauge steel
- Seams are continuously welded and ground smooth
- 3-point keylocking handle is provided on front, main door
- Double overlapping doors are provided on two door consoles
- Main hinged doors are flush
- Large sloping control panels are hinged along the bottom edge
- Control panels have captivated screws which thread into sealed wells

- Grounding provisions provided
- Door stops provided to hold control panel open
- Print pocket is provided
- Closed cell neoprene gasket is provided
- Removable back panel included with console
- Studs are welded to inside of console for mounting back panel
- An inclined body rail is welded to each side of 24.00" wide and 36.00" wide consoles for support of terminal straps

Construction—Top

- Fabricated from 14 gauge steel
- Tops has a sloped front surface
- Seams are continuously welded and ground smooth
- Instrument and access panels have captivated screws which thread into sealed well

- 4 holes are provided in bottom of top for mounting to body
- Closed cell neoprene gasket
- Instrument panels and access panels are removable

Construction—Writing Desk

- Fabricated from 14 gauge steel
- Seams are continuously welded and ground smooth
- Desks are removable and attach easily to console front

Finish

- ANSI 61 gray polyester powder inside and out over phosphatized surfaces
- Included back panel is white polyester powder over phosphatized surfaces

Accessories

- See pages J1-J19

WC12 SERIES OPERATOR INTERFACE CONSOLES					
CATALOG NUMBER CONSOLE ONLY	CONSOLE WIDTH	CATALOG NUMBER			BACK PANEL SIZE H X W
		CONSOLE TOP	WRITING DESK	CASKET KIT	
WC1224B	24" (610)	WC1224T	WC1224W	WC12C	32"x18" (813x457)
WC12B	36" (914)	WC12T	WC12W	WC12C	32"x30" (813x762)
WC1248BD	48" (1219)	WC1248T	WC1248W	WC12C	32"x42" (813x1067)



WC1224B & WC12B

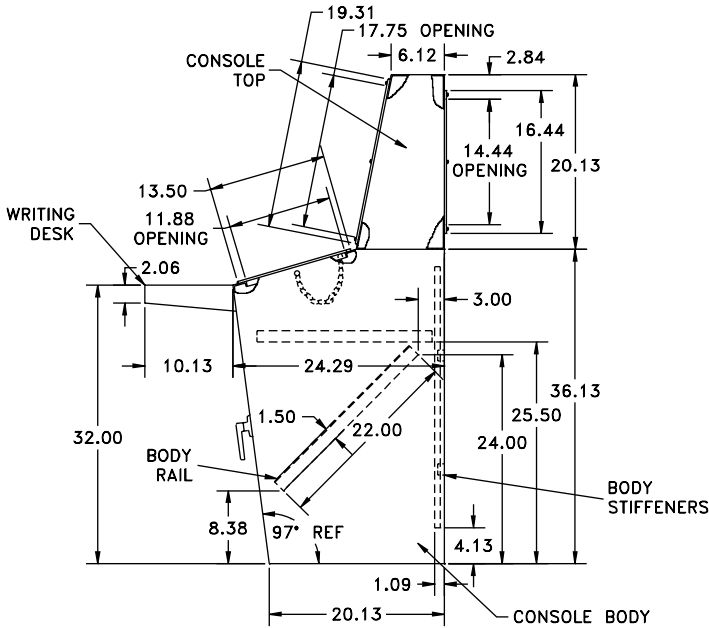
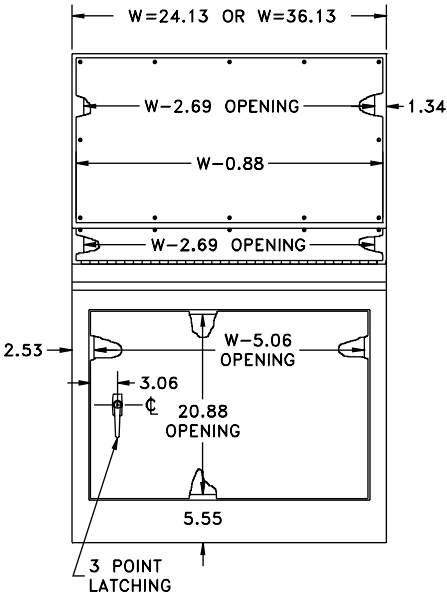

WC1248BD

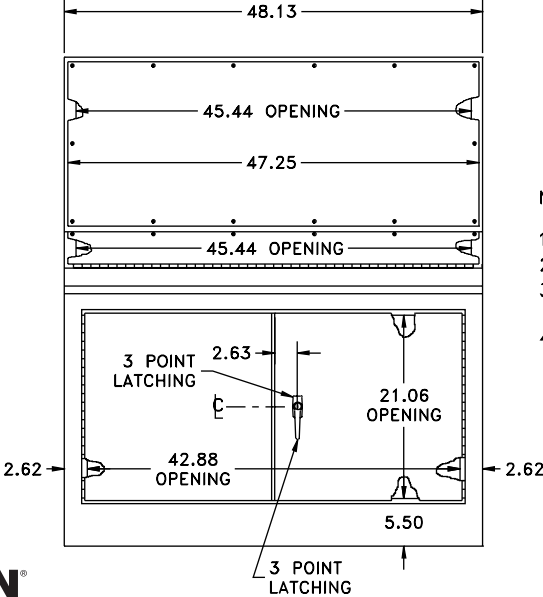

- Notes:
1. Access doors open 180 degrees.
 2. One 8X10 Print Pocket is provided.
 3. 3-point key-locking handles are provided on main doors.
 4. Writing desk is provided with mounting hardware.

